

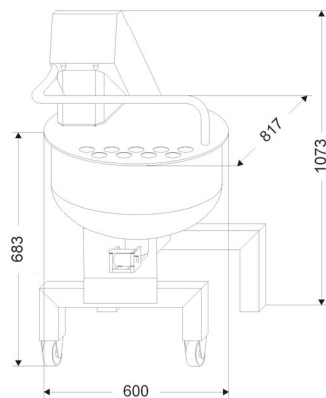

MÉLANGEURS

MIXERS





**Dimensions
PMX60 - PMX60CM**

PMX60 - PMX60CM

PMX60
Cuve entraînée par le produit

PMX60 CM
Cuve motorisée – 2 moteurs

Entièrement INOX 18-10

Bras relevable

Disponible avec bras démontable (sur demande)

Cuve basculante

Monté sur roulettes

Entièrement étanche – Nettoyage facile

Réducteur à bain de graisse

Couvercle de protection INOX

Conforme aux normes C.E.

PMX60
Bowl driven by the product

PMX60 CM
Motorized bowl – 2 motors

Entirely in stainless steel 18-10

Arm can be raised

Removable arm (available on request)

Tipping bowl

With the wheels

Entirely waterproof – Easy cleaning

Oil bath reducer (permanently oiled)

Lid of protection in stainless steel

Complies with CE norms



Position chargement
Loading position



Position nettoyage
Cleaning position

Options disponibles – Available Options:

- Tension :** MONO, 230V, 50Hz
- Fréquence – Frequency :** 60Hz
- Variateur de vitesse – Speed variator**
- Emballage export – Export packaging :**
Caisse bois – Woodenbox

Réf Ref	Tension Tension	Motor Motor	Contenance Capacity	Capacité de mélange Mixing capacity	Poids net Weight
PMX60	TRI, 400 V, 50 Hz	0,7 CV (0,5 Kw)	30 à 35 kg	8 à 35 kg	95 kg
PMX60CM	TRI, 400 V, 50 Hz	1 CV (0,75 Kw) + 0,5CV	30 à 35 kg	2 à 35 kg	105 kg



Mélangeurs

Mixers

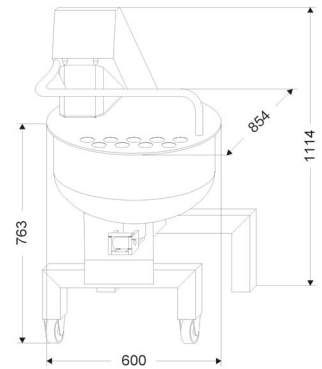

Dimensions
PMX90
PMX90CM



Position chargement
Loading position



Position nettoyage
Cleaning position

PMX90 - PMX90CM

PMX90
Cuve entraînée par le produit

PMX90 CM
Cuve motorisée – 2 moteurs

Entièrement INOX 18-10

Bras relevable

Disponible avec bras démontable (sur demande)

Cuve basculante

Monté sur roulettes

Entièrement étanche – Nettoyage facile

Réducteur à bain de graisse

Couvercle de protection

Conforme aux normes C.E.

PMX90
Bowl driven by the product

PMX90 CM
Motorized bowl – 2 motors

Entirely in stainless steel 18-10

Arm can be raised

Removable arm (available on request)

Tipping bowl

With the wheels

Entirely waterproof – Easy cleaning

Oil bath reducer (permanently oiled)

Lid of protection

Complies with CE norms

Options disponibles – Available Options:

Tension: MONO, 230V, 50Hz
Fréquence – Frequency: 60Hz
Variateur de vitesse – Speed variator
Emballage export – Export packaging:
Caisse bois – Woodenbox

Réf Ref	Tension Tension	Motor Motor	Contenance Capacity	Capacité de mélange Mixing capacity	Poids net Weight
PMX90	TRI, 400 V, 50 Hz	1 CV (0,75 Kw)	45 à 50 kg	8 à 50 kg	100 kg
PMX90CM	TRI, 400 V, 50 Hz	1 CV (0,75 Kw) + 0,5CV	45 à 50 kg	2 à 50 kg	110 kg